



REPASO Y EJERCICIOS

25. Haga un dibujo de tres vistas de una de las partes que se muestran en las figuras 6-6-F a 6-6-L. Permita que haya 1.00 in. o 25 mm entre las vistas. Escala 1:1. No acote.



Figura 6-6-F Bloque en almohada.



Figura 6-6-J Soporte de rodamiento.

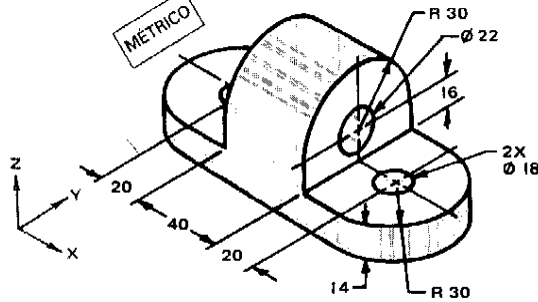

Figura 6-6-G Abrazadera guía.

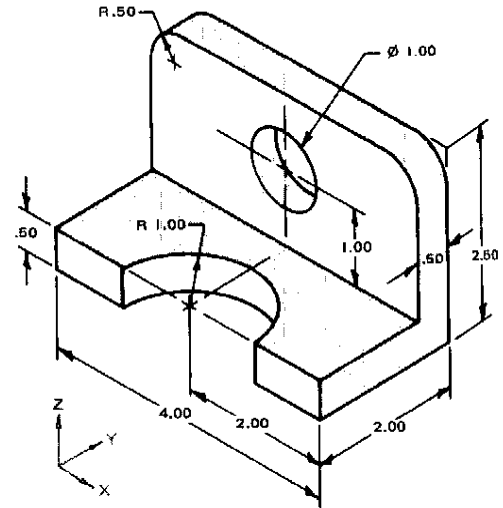

Figura 6-6-K Soporte de cuña.

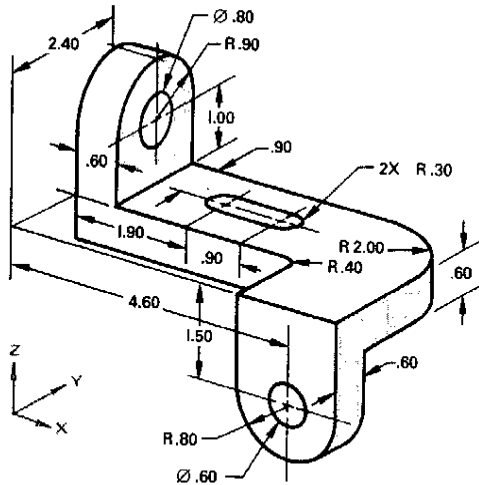

Figura 6-6-H Sostén de bisagra.

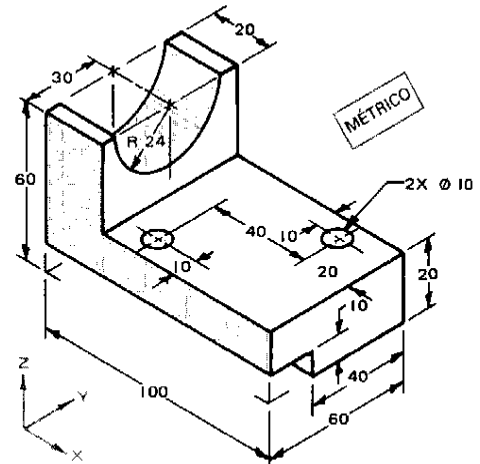
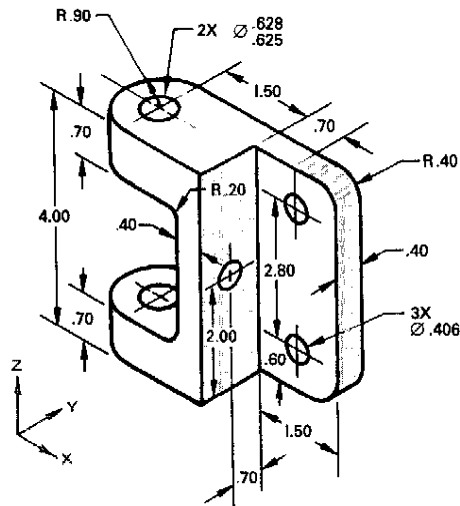
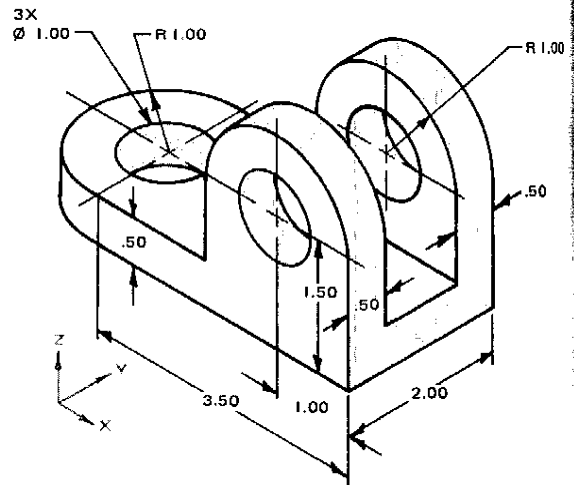

Figura 6-6-L Brazo oscilante.